

Product Manual

SCPK03-CIST19

Electronic Control WC Flush Cistern
with Infra-Red Sensor or Piezo Touch Button Activation.

wallgate.com

Wallgate
ROBUST. INNOVATIVE. WASHROOMS



For technical advice, or further information on Wallgate products, contact our sales or customer services department.

Tel: (01722) 744594

Fax: (01722) 742096 / 742933 (service)

Email: sales@wallgate.com / service@wallgate.com

Web: www.wallgate.com

Table of Contents

1. Disclaimer & Copyright Notice	3
2. Conventions	4
2.1. Warning.....	4
2.2. Note	4
2.3. Numbered procedures.....	4
2.4. Bullet lists	4
2.5. Menu items.....	4
3. Glossary.....	5
4. Product Contents.....	5
5. Fitting the Cistern	6
6. Fitting the Flush Pipe.....	7
7. Water Supply Connection to Cistern Fill Valve	9
8. Electrical Connection.....	12
9. Flush Valve Activation Touch Button or Infra-Red (IR) Sensor	12
10. Flush Volume Setting	13
11. Setting Flush Modes.....	13
12. Commissioning the Installed Cistern:.....	14

1. Disclaimer & Copyright Notice

Every effort has been made to supply information within this manual which is correct. Wallgate Limited will not be liable for any damage or loss that arises if the person installing, operating or maintaining the unit has not read or not complied with the manual.

In any event, and without prejudice to any warranties in Wallgate Limited's terms and conditions of sale, Wallgate Limited's liability for all damages and losses (including negligence) shall not in any circumstances exceed the amount paid by the customer for the unit.

Wallgate reserves the right to alter, update or improve its product specification at any time without prior notice. This manual is specific to the product that it has been supplied with at the date of supply.

Without prejudice to any warranties in Wallgate Limited's terms and conditions of sale, any warranty will be invalidated if the equipment is installed or serviced by unqualified personnel.

No part of this publication and the information contained may be reproduced, transmitted, stored in a retrieval system, used or disclosed wholly or partly without prior written permission from Wallgate Limited.

For full warranty details please see Wallgate Limited Terms and Conditions.

Please ensure this manual is passed to the end user. The manual forms an integral part of the product and should be kept for its working life. Additional copies of this and other supporting documents are available by contacting Wallgate Ltd or by visiting www.wallgate.com

2. Conventions

Certain conventions are used in this manual to make it easier to read and understand. It is recommended that you read and understand these warnings before you install and commission the WC.

2.1. Warning

A warning with white text on a red background is used to give information about hazards that can cause injury or death. Read and understand these warnings before you install and commission the SCPK-CIST19. Failure to heed these warnings can have serious consequences.

WARNING! This is a warning!

2.2. Note

A note with black text on a yellow background is used to draw your attention to important and useful information.

NOTE: This is a note.

2.3. Numbered procedures

Steps in procedures are numbered, starting from 1.

1. This is step 1.
2. This is step 2 etc.
- 2.4 Bullet lists

2.4. Bullet lists

- A bullet list is used to give information that is not sequential.

2.5. Menu items

Menu items, submenu items and settings, where available, are given in bold.

3. Glossary

The glossary lists all words, abbreviations and technical terminology used in this manual, along with a short description of these terms.

Term	Description
IR Sensor	The infrared (IR) sensor transmits an invisible beam, so that when interrupted by a person's hand the beam is rebounded back to the receive sensor. This creates an electrical signal which rapidly activates the cistern flush.
Piezo electric touch button	A piezo electric touch button converts the force applied to the face of the touch button into an electrical signal. Piezoelectric touch buttons are used to operate the cistern flush.
BSP	The British Standard Pipe (BSP) thread is a family of standard screw thread types that has been adopted internationally for interconnecting and sealing pipe ends by mating an external (male) with an internal (female) thread ¹ .

¹ Description sourced from Wikipedia at http://en.wikipedia.org/wiki/British_standard_pipe_thread

4. Product Contents

1 x SCPK03 including:

- 3 x Electronic cistern CIST19-ELEC.
- 3 x Cistern kit for SCPK including flush module, flush pipe (500mm), flush pipe WC pan seal & cistern wall brackets & cistern cover plate.
- 3 x Single flush IR sensor or piezo touch button.
- 1 x Mains Electric Power Adapter.
- 1 x Mains cable.
- 1 x Wall plate for power supply adapter.
- 1 x Cable Tie (300mm).
- 1 x DC power supply splitter 4:1.
- 3 x DC power supply 3m extension cable.

5. Fitting the Cistern

NOTE: The wall construction must be suitable to support the cistern weight when full: 10kg

NOTE: Refer to the cistern manufacturer instructions packed with the cistern in conjunction to following these instructions.

1. Assemble the support and wall brackets and fit them to the cistern (Fig: 3).
2. Mark wall position so the cistern is vertically central to WC pan and at a height as shown on fig 1.

NOTE 1: The dimension from the flush inlet to floor level will vary according to the model of the WC pan. Refer to the drawing of the WC pan for the correct dimension.

3. Mark positions for cistern screw fixing points using cistern and bracket as template.
4. Select appropriate wall fixings for wall type, screws of size 5mm x 40mm long with a round head are recommended.
5. Drill holes and fit cistern to wall.

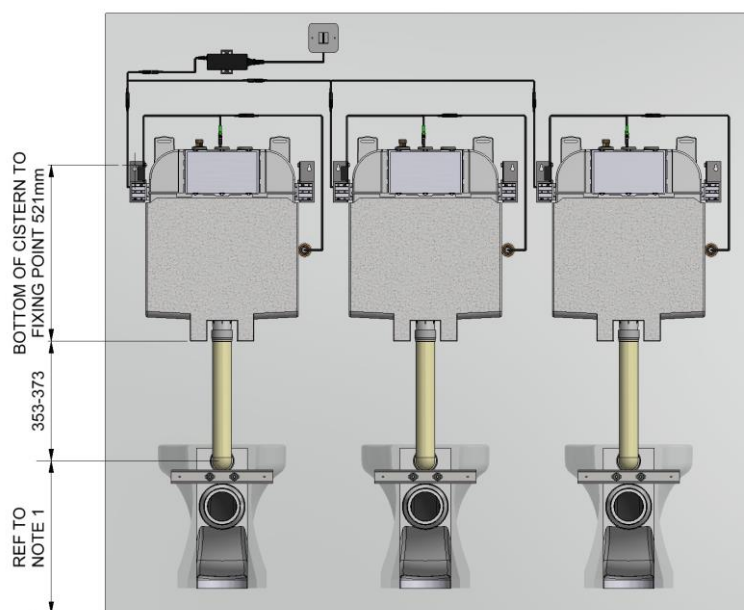
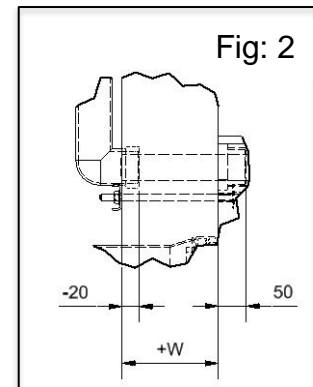

Fig: 1

6. Fitting the Flush Pipe

Two lengths of flush pipe (280 & 500mm) are supplied for the horizontal connection between the vertical cistern flush pipe and the WC pan.

1. Select the most appropriate length pipe to suit and if required cut it to reduce the horizontal length into the back of the WC pan.
2. Mark the position for the cut allowing for:
 - a. 50mm of pipe into the WC pan,
 - b. The wall thickness (W),
 - c. 20mm to insert into vertical flush pipe as shown on fig 2.



NOTE: If the WC pan is fitted with an extension then the extension length should also be included.

3. Cut the pipe using a fine-tooth panel saw to ensure a straight clean cut, ensure cut of pipe is made clean and straight with all burrs removed.

NOTE: The use of a hacksaw is NOT recommended.

4. To fit the flush pipes firstly push the vertical pipe onto the outlet spigot of the cistern and then fit the horizontal pipe into the socket of the vertical pipe.
5. Fit the WC pipe seal onto the end of horizontal pipe (Note correct seal orientation). Press the pipe with seal into the WC pan fully up to the barrier stop. The polystyrene pipe cover can then be fitted to the vertical pipe, again cut the cover with a fine-tooth panel saw should its length require shortening.

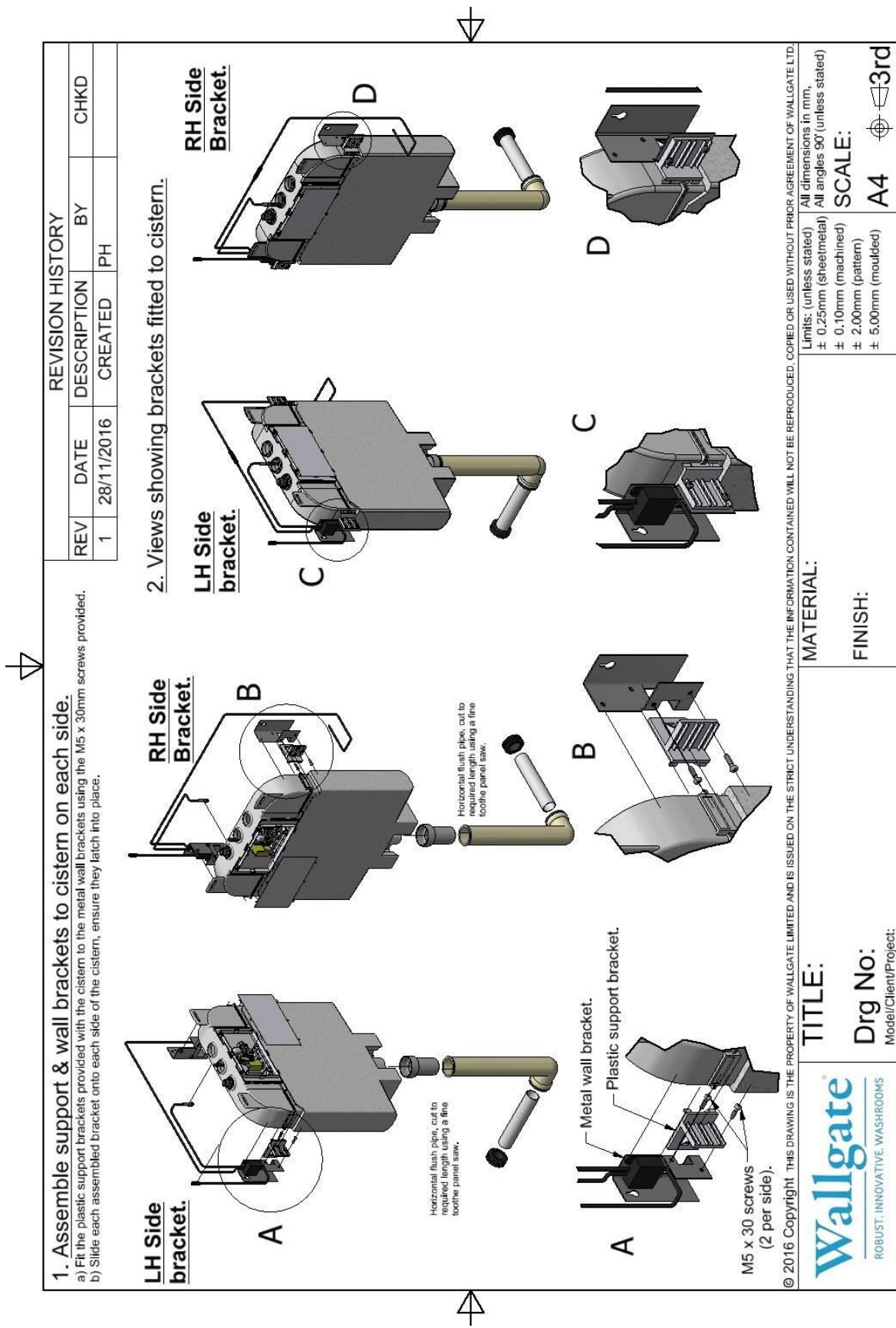

Fig: 3

7. Water Supply Connection to Cistern Fill Valve

NOTE:

- **Water supply dynamic pressure: 0.1 – 14 Bar dynamic.**
 - **Maximum static pressure: 20 Bar.**
 - **Flush out water pipes to remove building debris and air locks prior to connecting it to the cistern fill valve.**
1. Assemble the water inlet / stop tap in left hand aperture on top of the cistern. Shown on manufacturers instruction sheet instruction 2, packed with the cistern.
 2. Connect a cold-water supply to the inlet connector (Size ½" BSP (M)). The inclusion of a service stop tap in the supply pipe close to the cistern is recommended.

As the incorrect installation of water fittings may result in contravention of Water Byelaws or Regulations the following INSTALLATION REQUIREMENTS & NOTES (IRNs) are intended as guides to Water Suppliers, Installers and their customers.

NOTE: Please ensure these requirements are checked at time of installation.

IRNs related to this product:

- IRN 160 - A compliant double check valve or some other no less effective device providing backflow prevention protection to at least fluid category three shall be fitted at the point of connection(s) between the water supply and the fitting or appliance.
- IRN 280 - A servicing valve shall be installed on the supply to the fitting in a readily accessible location.
- IRN 390 - An inlet strainer or line strainer shall be provided at the inlet.

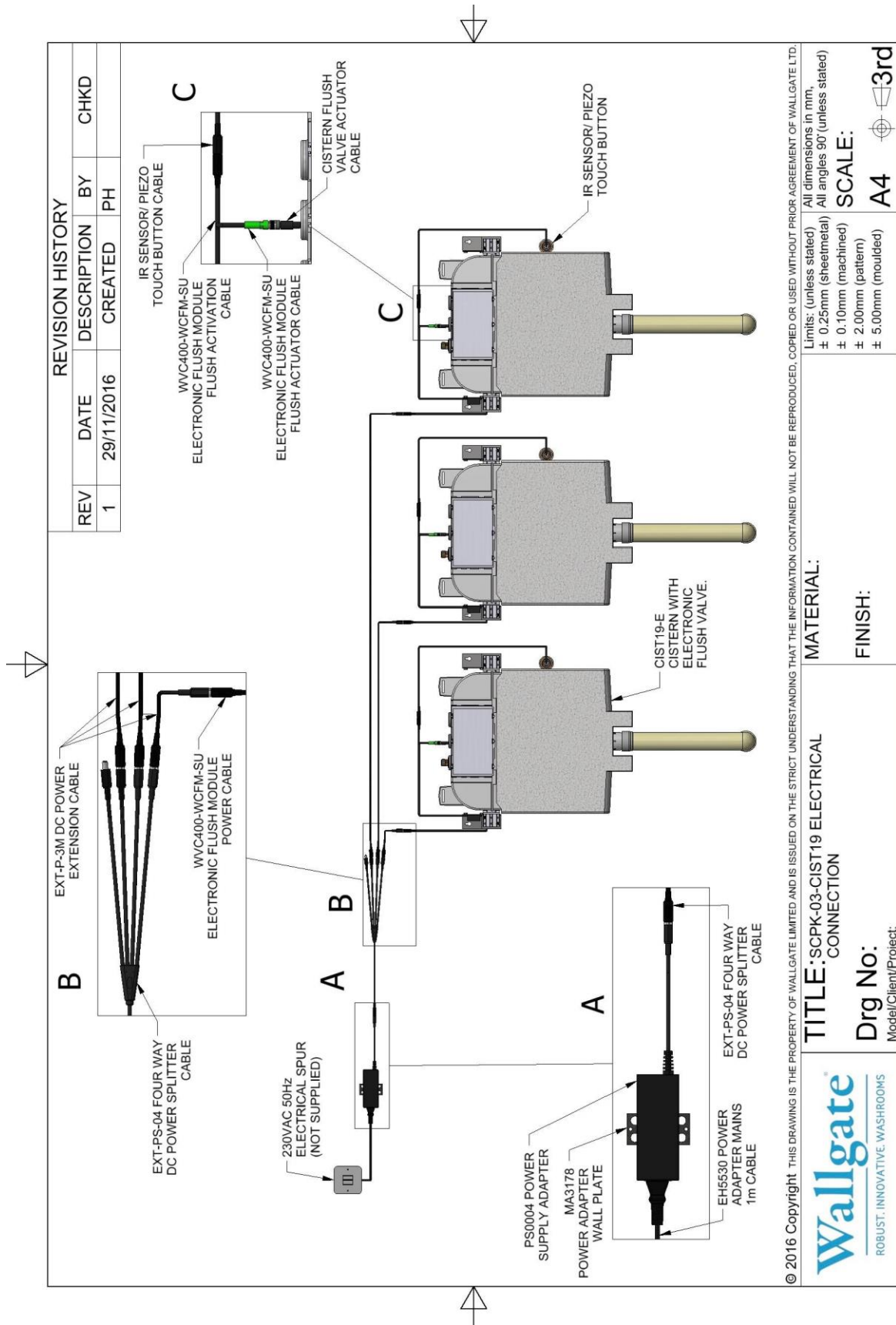

© 2016 Copyright THIS DRAWING IS THE PROPERTY OF WALLGATE LIMITED AND IS ISSUED ON THE STRICT UNDERSTANDING THAT THE INFORMATION CONTAINED WILL NOT BE REPRODUCED, COPIED OR USED WITHOUT PRIOR AGREEMENT OF WALLGATE LTD.

TITLE: SCPK-03-CIST19 ELECTRICAL CONNECTION

Drg No:

Model/Client/Project:

Wallgate
ROBUST. INNOVATIVE. WASHROOMS

t: +44 (0) 1722 744 594 f: +44 (0) 1722 742 096 e: sales@wallgate.com w: www.wallgate.com Company Reg No. 156022

Fig: 4 (Typical installation layout)

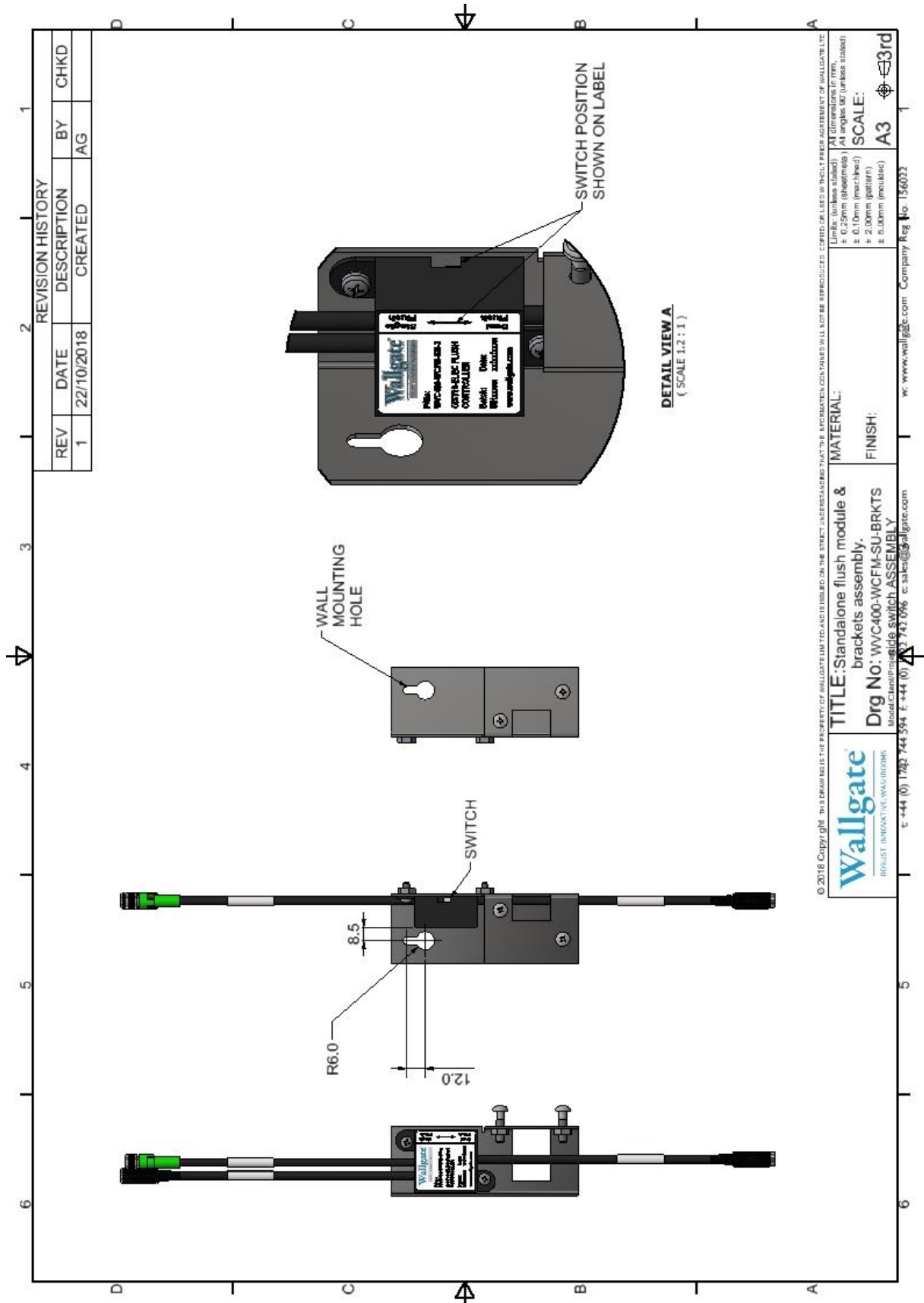

Fig: 5 (flush control mounting with switch position)

8. Electrical Connection

1. The flush valve is controlled electronically by a flush module which is located on the left hand mounting bracket. The cable is routed from the flush valve, out of the top of the cistern for connection to the coloured socket on the flush activation cable from the flush module (Fig 4). Ensure the pins on the connector are correctly aligned before mating them together and secure with the locking ring.
2. Then connect the power cable from the bottom of the electronic module to 3m DC power extension cable (EXT-P-3M).
3. Connect the 3m DC power extension cable (EXT-P-3M) to the four-way DC power splitter cable (EXT-PS-04).
4. Repeat steps 1-3 for the second and third cistern.
5. Connect the DC power splitter cable (EXT-PS-04) to the power supply adapter (PS0004).
6. Connect the power supply adapter (PS0004) to the power adapter mains cable (EH5530).
7. Install power adapter mains cable into 230VAC electrical spur (not supplied) or suitably approved equivalent.

9. Flush Valve Activation Touch Button or Infra-Red (IR) Sensor

A Wallgate touch button or IR sensor (Fig 4) is used for the activation of the cistern flush valve once connected to the flush module. The touch button or sensor will be wall mounted alongside the WC pan at an appropriate position for use. Refer to the instructions or drawing supplied with the touch button or sensor for installation and connection to the control unit.

10. Flush Volume Setting

NOTE: By default, the cistern is set to give a 6-litre flush as supplied.

This can be adjusted as follows:

Setting the blue lever to the minus (-) position gives a 6-litre flush

Setting the blue lever to the plus (+) position gives a 7-litre flush.

See images below (Fig: 5).

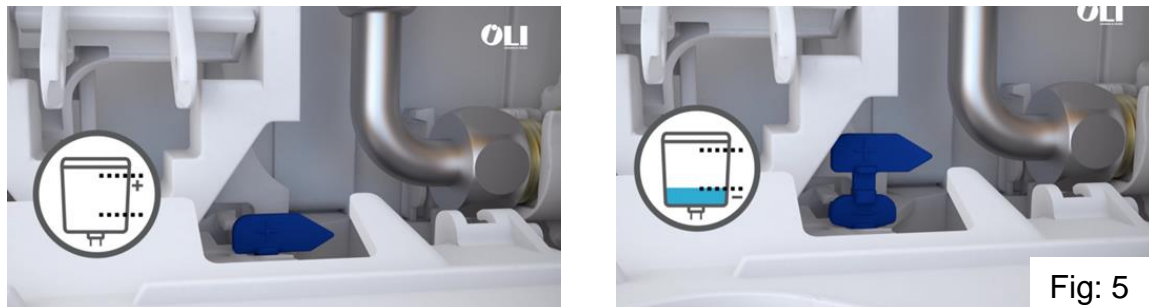

11. Setting Flush Modes

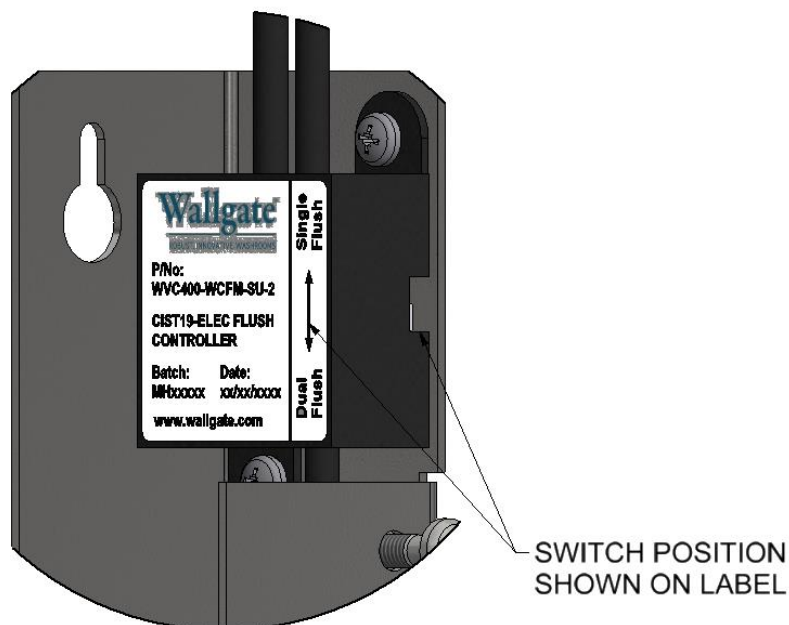

NOTE: If using dual flush mode, instructions of how to use each mode must be clearly displayed. A button bezel with instructions is available from Wallgate.

Flush modes can be switched to provide either;

- A single full flush per button press
- A reduced volume flush with a single press and a full flush upon a double press of the button.

NOTE: The flush mode should be set BEFORE installation if access to the module may be restricted during or after installation.

To change the mode;

1. Put the switch on the module into the position for the desired flush operation.
2. Power down the module, wait for power supply to fully discharge,
3. Turn on the power for the module (make sure the switch remains in the desired position while the module powered on).

The module will remain in the same mode until it is restarted by turning the power on and off.

NOTE: To ensure correct dual/single flush operation it is advised to leave the selector switch in the desired position in case of power outage.

12. Commissioning the Installed Cistern:

NOTE: If the water system has been treated with chemical dosing, ensure the system is thoroughly flushed before fitting this product. Concentrated chemicals in dead legs can damage the product & result in failure. If the water is treated with Chlorine Dioxide (ClO₂), ensure concentration levels do not exceed a solution of 100 ml of domestic chlorine-based bleaching agent, consisting of up to 5% sodium hypochlorite (NaClO) and anionic surfactants to every 900 ml of water.

To operate the wc flush:

1. Turn ON the cold-water supply & check that there are no leaks.
2. Check that the cistern has filled.
3. Activate a flush by pressing on the touch button or if an IR sensor is fitted then place your hand in front of the sensor (within 50mm). Check the flush operates correctly and note that there is a 30 second delay before a repeat flush will operate to allow the cistern to refill.
4. Repeat the flush three times to ensure consistency. If the product model supplied includes a reduced flush as well as a full flush, then also operate the reduced flush to ensure its operation is correct.

NOTE: The default flush volume is 6 litres for a full flush and 3.5 litres for the

reduced flush.

5. On completion of commissioning the cistern cover plate must be fitted.
6. Ensure that the wiring to the flush valve will not become trapped when the cover plate is fitted, the connector should be located outside of the cistern.

Notes:

PAGE INTENTIONALLY LEFT BLANK

PAGE INTENTIONALLY LEFT BLANK



Wallgate Ltd.

Crow Lane, Wilton,
Salisbury, Wiltshire,
SP2 0HB, England

tel: +44 (0) 1722 744594

fax: +44 (0) 1722 742096

email: service@wallgate.com

web: www.wallgate.com

[wallgate.com](http://www.wallgate.com)

Revision 3

Wallgate[®]
ROBUST. INNOVATIVE. WASHROOMS